

RUSH MH 7 Hybrid

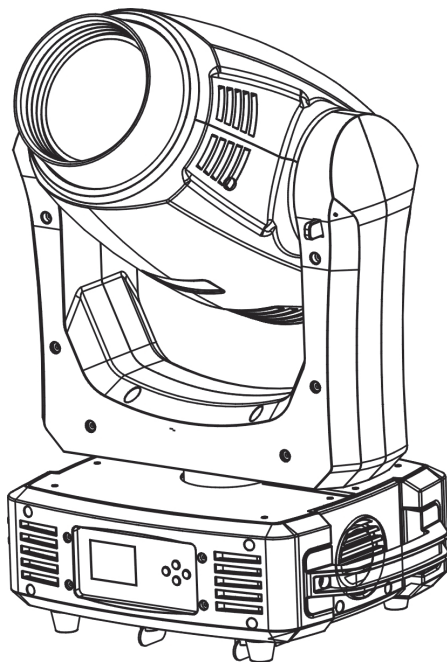

User Manual

Martin[®]
by HARMAN

© 2016 Martin Professional™ ApS. Information subject to change without notice. Martin Professional™ and all affiliated companies disclaim liability for any injury, damage, direct or indirect loss, consequential or economic loss or any other loss occasioned by the use of, inability to use or reliance on the information contained in this manual. RUSH™, Martin™, Harman™ and all other trademarks in this document pertaining to services or products by Martin Professional™ or its affiliates and subsidiaries are registered as the property of Harman International Industries.

Martin Professional • Olof Palmes Allé 18 • 8200 Aarhus N • Denmark • www.martin.com

RUSH MH 7 Hybrid User Manual: Revision D

Table of contents

Safety information.....	4
Introduction.....	10
Before using the product for the first time.....	10
Maximizing lamp life.....	10
Physical installation.....	11
Fastening the fixture to a flat surface.....	11
Mounting the fixture on a truss.....	11
AC power.....	13
Linking fixtures to power in a chain.....	14
Fixture overview.....	15
Control data link.....	16
Tips for reliable data transmission.....	16
Connecting the data link.....	16
Fixture setup.....	17
Using the control menus.....	17
DMX address.....	17
Lamp settings.....	17
Fixture settings.....	18
Fixture readouts.....	21
Offset menu.....	21
Effects.....	22
Hybrid functionality.....	22
Dimming.....	22
Strobe effects.....	22
Gobos.....	23
Colors.....	25
Prisms.....	25
Frost.....	25
Focus.....	25
Zoom.....	25
Pan and tilt.....	26
Maintenance.....	27
Cleaning.....	27
Replacing gobos.....	28
Lamp replacement.....	30
Replacing the primary fuse.....	32
Service and repairs.....	32
DMX protocol.....	33
Control menus.....	38
Troubleshooting.....	40
Specifications.....	41

Safety information



WARNING!

Read the safety precautions in this manual before installing, operating or servicing this product.

The following symbols are used to identify important safety information on the product and in this manual:



Warning!

Safety hazard. Risk of severe injury or death.



Warning!

Powerful light emission. Risk of eye injury.



Warning!

See user manual for important safety information.



Warning!

Hazardous voltage. Risk of lethal or severe electric shock.



Warning!

Hot surfaces.



Warning!

Fire hazard.



Warning! Risk Group 3 (high risk) product according to EN 62471. Possibly hazardous radiation emitted from this product. May be harmful to the eyes. Do not stare at operating lamp and do not view the light output with optical instruments or any device that may concentrate the beam.

This lighting fixture is for professional use only and must be installed by a qualified technician. It is not for household use. It presents risks of severe injury or death due to fire hazards, electric shock and falls. It produces a powerful, concentrated beam of light that can create a fire hazard or a risk of eye injury if the safety precautions below are not followed.



Install, operate and service Martin™ products only as directed in their user manuals, or you may create a safety hazard or cause damage that is not covered by product warranties.

Follow the safety precautions listed below and observe all warnings in this manual and printed on the product. Keep this user manual for future use.

For the latest user documentation and other information for this and all Martin™ products, please visit the Martin website at <http://www.martin.com>

If you have any questions about how to install, operate or service the fixture safely, please contact your Martin™ distributor (see www.martin.com/distributors for details) or call the Martin™ 24-hour service hotline on +45 8740 0000, or in the USA on 1-888-tech-180.

Respect all locally applicable laws, codes and regulations when installing, operating or servicing the fixture.



Protection from electric shock

Do not expose the fixture to rain or moisture.

Disconnect the fixture from AC power before carrying out any installation or maintenance work and when the fixture is not in use.

Ensure that the fixture is electrically connected to ground (earth).

Use only a source of AC power that complies with local building and electrical codes and has both overload and ground-fault (earth-fault) protection.

Socket outlets or external power switches used to supply the fixture with power must be located near the fixture and easily accessible so that the fixture can easily be disconnected from power.

Replace defective fuses with ones of the specified type and rating only.

Isolate the fixture from power immediately if the power plug or any seal, cover, cable, or other component is damaged, defective, deformed, wet or showing signs of overheating. Do not reapply power until repairs have been completed.

Before using the fixture, check that all power distribution equipment and cables are in perfect condition and rated for the electrical requirements of all connected devices.

Use only Neutrik PowerCon cable connectors to connect to power sockets.

Do not connect devices to power in a chain that will exceed the electrical ratings of any cable or connector used in the chain.

The supplied power input cable is rated 9 A and can safely supply only one fixture with mains power. Do not connect any device to the fixture's MAINS OUT connector when using this cable. If you replace this cable and also use the replacement cable to supply only one fixture with mains power, the replacement cable must also be rated 9 A minimum, have three conductors 18 AWG or 0.75 mm² minimum conductor size, have an outer cable diameter of 6 - 15 mm (0.2 - 0.6 in.) and be temperature-rated to suit the application. In the USA and Canada the cable must be UL listed, type SJT or equivalent. In the EU the cable must be type H05VV-F or equivalent.

To connect fixtures to mains power in a chain, you must first obtain 14 AWG or 1.5 mm² power input and throughput cables that are 16 A rated and temperature-rated to suit the application. In the USA and Canada the cables must be UL-listed, type SJT or equivalent. In the EU the cables must be type H05VV-F or equivalent. Suitable cables with Neutrik PowerCon connectors are available from Martin™ (see 'Accessories' on page 43). If you use these cables, you can connect fixtures to power in a linked chain, MAINS OUT throughput socket to MAINS IN input socket, but do not link more than:

- two (2) RUSH MH 7 Hybrid fixtures in total at 100-120 V, or
- four (4) RUSH MH 7 Hybrid fixtures in total at 200-240 V.

The voltage and frequency at the MAINS OUT socket are the same as the voltage and frequency applied to the MAINS IN socket. Only connect devices to the MAINS OUT socket that accept this voltage and frequency.



Protection from burns and fire

Do not operate the fixture if the ambient temperature (T_a) exceeds 40° C (104° F).



The surface of the product casing can reach up to 100° C (212° F) during operation. Avoid contact by persons and materials. Allow the fixture to cool for at least 10 minutes before handling.

Keep flammable materials well away from the fixture. Keep all combustible materials (e.g. fabric, wood, paper) at least 0.2 m (8 in.) away from the fixture head.

Ensure that there is free and unobstructed airflow around the fixture. Provide a minimum clearance of 0.5 m (20 in.) around fans and air vents.

Do not illuminate surfaces within 10 m (33 ft.) of the fixture.

Do not attempt to bypass thermostatic switches or fuses.

Do not stick filters, masks or other materials onto any optical component.

The fixture's lenses can focus the sun's rays inside the fixture, creating a risk of fire and damage. Do not expose the front of the fixture to sunlight or any other bright light source.



Protection from injury

Fasten the fixture securely to a fixed surface or structure when in use. The fixture is not portable when installed.

Ensure that any supporting structure and/or hardware used can hold at least 10 times the weight of all the devices they support.

If suspending from a rigging structure, fasten two (2) suitable rigging clamps to the fixture as described in this manual. Do not use safety cables as the primary means of support.

If the fixture is installed in a location where it may cause injury or damage if it falls, install as directed in this manual a secondary attachment such as a safety cable that will hold the fixture if a primary attachment fails. The secondary attachment must be approved by an official body such as TÜV as a safety attachment for the weight that it secures, must comply with EN 60598-2-17 Section 17.6.6 and must be capable of bearing a static suspended load that is ten times the weight of the fixture and all installed accessories.

Allow enough clearance around the head to ensure that it cannot collide with an object or another fixture when it moves.

Check that all external covers and rigging hardware are securely fastened.

Block access below the work area and work from a stable platform whenever installing, servicing or moving the fixture.

Do not operate the fixture with missing or damaged covers, shields or any optical component.

Do not lift or carry the fixture by its head. Support the fixture by its base only.

In the event of an operating problem, stop using the fixture immediately and disconnect it from power. Do not attempt to use a fixture that is obviously damaged.

Do not modify the fixture in any way not described in this manual or install other than genuine Martin™ parts.

Refer any service operation not described in this manual to a qualified technician.



Lamp safety

Install only a lamp that is approved by Martin™ for use in the product.



Prolonged exposure to an unshielded discharge lamp can cause eye and skin burns. Do not look at an exposed lamp while it is lit. Do not operate the fixture with missing or damaged covers, shields, lenses, ultraviolet screens or any optical component.



A hot discharge lamp is under pressure and can explode without warning. Allow the fixture to cool for at least 1 hour before handling a lamp and protect yourself with safety glasses and gloves.

Replace the lamp immediately if it becomes visually deformed, damaged or in any way defective.

Monitor hours of lamp use. Replace the lamp before or when it reaches its average lifetime as specified in this manual or by the lamp manufacturer or if you notice a fall in light output. If you exceed the average lamp lifetime, the lamp may explode and damage the fixture.

If the quartz envelope of a discharge lamp is broken, the lamp releases a small quantity of mercury and other toxic gases. If a discharge lamp explodes in a confined area, evacuate the area and ventilate it thoroughly for 30 minutes. Wear nitrile gloves when handling a broken discharge lamp. Do not use a vacuum cleaner to remove pieces of a broken lamp. Treat broken or used discharge lamps as hazardous waste: put them in a plastic bag and send to a specialist for disposal.



Protection from eye injury

Warning! Risk Group 3 (high risk) product according to EN 62471. Possibly hazardous optical radiation emitted from this product.



Do not look directly into the product's light output.

Do not look at operating lamp. Eye injury may result.

Do not expose persons to the product's light output from a distance of less than 1.5 m (5 ft.).

Avoid eye or skin exposure to unshielded product. UV emitted from this product.

Do not look at the light output with magnifiers, telescopes, binoculars or similar optical instruments that may concentrate the light output.

Ensure that persons are not looking directly into the front of the fixture when the product lights up suddenly. This can happen when power is applied, when the product receives a DMX signal, or when certain control menu items are selected.

To minimize the risk of eye irritation or injury, disconnect the fixture from power at all times when the fixture is not in use and provide well-lit conditions to reduce the pupil diameter of anyone working on or near the fixture.

Introduction

The RUSH™ MH 7 Hybrid is a powerful fixture with a high-intensity beam from a Philips MSD Platinum 11R 250W short-arc discharge lamp. Designed to be versatile, the RUSH™ MH 7 Hybrid gives you the flexibility of Beam, Spot and Wash functionality. Its moving head is packed with motorized focus and 1:6 zoom, smooth full-range dimming, a strobing shutter and pulse effects, 12 static gobos, 8 user-replaceable rotating gobos, 13 color filters, 2 rotating prisms and a frost filter. It provides 540° of pan and 250° of tilt. The short-arc source and multiple effects make it ideal for live shows, TV events, stage, concerts, and nightclubs.

The RUSH MH 7 Hybrid can be controlled using any DMX-compliant controller. It is supplied with a 1.5 m (5 ft.) power cable ready for a local power plug (not included) and two mounting brackets for attachment of suitable, user-supplied rigging clamps.

Before using the product for the first time

1. Read 'Safety information' on page 4 before installing, operating or servicing the fixture.
2. Unpack and ensure that there is no transportation damage before using the fixture. Do not attempt to operate a damaged fixture.
3. If the fixture is not going to be hard-wired to a mains supply, install a local power plug (not supplied) on the end of the supplied power cable.
4. Ensure that the voltage and frequency of the power supply match the power requirements of the fixture.
5. Check the support pages on the Martin Professional website at www.martin.com for the most recent user documentation and technical information about the fixture. Martin™ user manual revisions are identified by the revision letter at the bottom of the inside cover.

Note that whenever AC power is applied to the fixture, it will reset all effects and functions to their home positions. Be prepared for the fixture head to move. A reset usually takes around 50 seconds.

Maximizing lamp life

To obtain maximum output over the lifetime of the fixture's lamp:

- Each time you power the lamp on, allow it to warm up for at least 5 minutes before you power it off.
- Before shutting down power completely, power the lamp off but leave power applied to the fixture for a few minutes so that cooling fans can prevent any momentary lamp temperature increase caused by heat from surrounding components.

Physical installation



Warning! Read 'Safety information' on page 4 before installing the fixture.

The fixture is designed for indoor use only and must be used in a dry location with adequate ventilation. Ensure that none of the fixture's ventilation slots are blocked.

Fasten the fixture to a secure structure or surface. Do not stand it on a surface or leave it where it can be moved or fall over. If you install the fixture in a location where it may cause injury or damage if it falls, secure it as directed in this user manual using a securely anchored safety cable that will hold the fixture if the primary fastening method fails.

Do not use the fixture to illuminate surfaces within 10 m (33 ft.) of the fixture.

Martin™ can supply safety cables and rigging clamps that are suitable for use with the fixture (see 'Accessories' on page 43).

Fastening the fixture to a flat surface

The fixture can be fastened to a hard, fixed, flat surface. Ensure that the surface and all fasteners used can support at least 10 times the weight of all fixtures and equipment they will support.

Fasten the fixture securely. Do not stand it on a surface or leave it where it can be moved or fall over. If you install the fixture in a location where it may cause injury or damage if it falls, secure it as directed below with a securely anchored safety cable that will hold the fixture if the primary fastening method fails.

Mounting the fixture on a truss

The fixture can be clamped to a truss or similar rigging structure in any orientation. When installing the fixture hanging vertically down, you can use an open-type clamp such as a G-clamp. When installing in any other orientation, you must use a closed-type rigging clamp such as half-coupler clamp (see illustration on right) that completely encircles the truss chord.



To clamp the fixture to a truss:

1. Check that the rigging structure can support at least 10 times the weight of all fixtures and equipment to be installed on it.
2. Block access under the work area.

3. The fixture is supplied with two omega-type brackets to which rigging clamps can be attached. Check that the rigging clamps are undamaged and approved for the fixture's weight. Bolt a rigging clamp securely to each bracket. The bolts used must be M12, grade 8.8 steel minimum, and fastened with self-locking nuts.
4. Fasten the omega brackets to the base of the fixture using the brackets' quarter-turn fasteners. Turn quarter-turn fasteners a full 90° to lock them (see illustration on right).
5. Working from a stable platform, hang the fixture on the truss and fasten the rigging clamps onto the truss.
6. Secure the fixture with a safety cable as directed below.
7. Check that the head will not collide with other fixtures or objects.

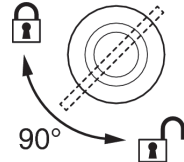

Securing with a safety cable

Secure the fixture with a safety cable (or other secondary attachment) that is approved for the weight of the fixture so that the safety cable will hold the fixture if a primary attachment fails.

Loop the safety cable through the eye bracket in the fixture's baseplate (see illustration below) and around a secure anchoring point.

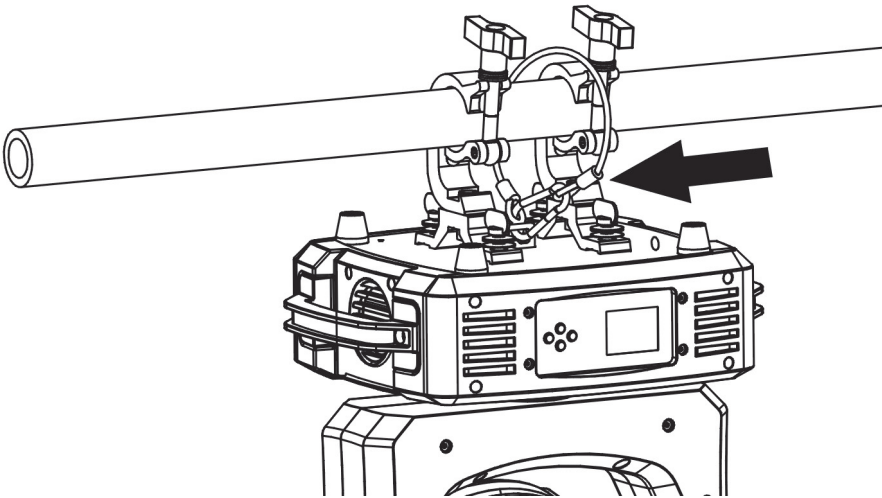

AC power



Warning! Read ‘Safety information’ on page 4 before connecting the fixture to AC mains power.



Warning! The mains power input cable supplied with the fixture is rated 9 A and can supply only one fixture with mains power. Do not connect any device to the fixture’s MAINS OUT power throughput socket when using this input cable. If you wish to connect other fixtures to the MAINS OUT socket, see ‘Linking fixtures to power in a chain’ on page 14.

For protection from electric shock, the fixture must be grounded (earthed). The power distribution circuit must be equipped with a fuse or circuit breaker and ground-fault (earth-fault) protection.

Do not insert or remove live Neutrik PowerCon connectors to apply or cut power, as this may cause arcing at the terminals that will damage the connectors.

Socket outlets or external power switches used to supply the fixture with power must be located near the fixture and easily accessible so that the fixtures can easily be disconnected from power.

Do not use an external dimming system to supply power to the fixture, as this may cause damage to the fixture that is not covered by the product warranty.

The fixture can be hard-wired to a building electrical installation if you want to install it permanently, or a power plug (not supplied) that is suitable for the local power outlets can be installed on the power cable.

If you install a power plug on the power cable, install a grounding type (earthed) plug with integral cable grip that is rated minimum 250 V, 9 A. Follow the plug manufacturer’s instructions and connect the wires in the power cable as shown in this table:

	Live or L	Neutral or N	Earth, Ground or Ⓧ
US system	Black	White	Green
EU system	Brown	Blue	Yellow/green

The fixture has an auto-ranging power supply that accepts AC mains power at 100-240 V at 50/60 Hz. Do not apply AC mains power at any other voltage or frequency to the fixture.

Linking fixtures to power in a chain

The mains power input cable supplied with the fixture is rated 9 A and can supply only one fixture with mains power. If you wish to connect fixtures to power in a linked chain, you must obtain a 14 AWG or 1.5mm² power input cable and 14 AWG or 1.5mm² throughput cables from Martin™ (see 'Accessories' on page 43).

Using these heavier gauge cables, you can relay mains power from one RUSH™ MH 7 Hybrid fixture to another RUSH™ MH 7 Hybrid fixture by connecting fixtures to power in a linked daisy-chain, MAINS OUT throughput socket to MAINS IN input socket, but do not exceed the following safety limits:

Using 14 AWG or 1.5 mm² cables from Martin™, you can link:

- **Maximum two (2)** RUSH™ MH 7 Hybrid fixtures in total at 100-120 V, or
- **Maximum four (4)** RUSH™ MH 7 Hybrid fixtures in total at 200-240 V.

If you install a power plug on the 14 AWG / 1.5 mm² power input cable, install a grounding type (earthed) plug with integral cable grip that is rated minimum 20 A, 250 V.

Fixture overview

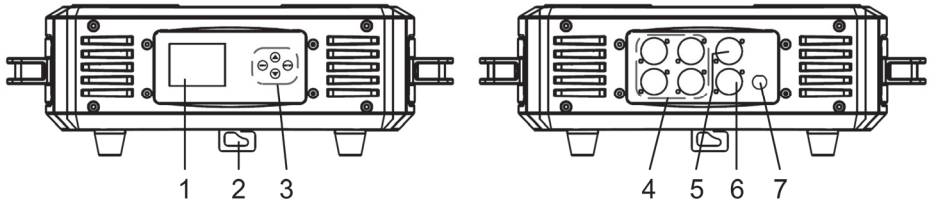

1 – LCD Display

While operating, the screen displays the fixture's DMX address. The address flashes if the DMX signal is lost. The display automatically turns off after a user-settable delay.

2 – Secondary attachment point

A dedicated eye bracket is provided for securing a safety cable to the base. Do not use the handles for secondary attachment.

3 – Control buttons

- MENU: Press to activate the menu. Within the menu, press to escape and return to the previous level. Press and hold to exit the menu.
- DOWN: Press to scroll down through menu options.
- UP: Press to scroll up through menu options.
- ENTER: Press to confirm and save the menu selection. Press and hold to exit the menu.

4 –XLR DMX input/output sockets

3 and 5-pin XLR sockets are provided for DMX input and output (throughput).

5 – Mains power input

Connect mains power to the blue Neutrik PowerCon input socket.

6 – Mains power throughput

The white Neutrik PowerCon socket can be used to supply power to other fixtures only if you respect the safety precautions given in this manual (see 'Safety information' on page 4).

7 – Main Fuse

The fixture's 5T 250V 8A fuse is located in a fuse holder next to the power input/output connectors.

Control data link

A DMX 512 data link is required in order to control the fixture via DMX. The fixture has 3-pin and 5-pin XLR connectors for DMX data input and output.

Up to 32 devices can be linked together on a single daisy chain. The total number of fixtures in one 512-channel DMX universe is limited by the number of DMX channels required by the fixtures. Note that if independent control of a fixture is required, it must have its own DMX channels. Fixtures that are required to behave identically can share the same DMX address and channels. To add more fixtures or groups of fixtures when the above limits are reached, add a DMX universe and/or split the daisy-chained link into branches.

Tips for reliable data transmission

Use shielded twisted-pair cable designed for RS-485 devices: standard microphone cable cannot transmit control data reliably over long runs. 24 AWG cable is suitable for runs up to 300 meters (1000 ft.). Heavier gauge cable and/or an amplifier is recommended for longer runs. The pin-out on all connectors is pin 1 = shield, pin 2 = cold (-), and pin 3 = hot (+). Pins 4 and 5 in the 5-pin XLR connectors are not used in the fixture but are available for possible additional data signals as required by the DMX512-A standard. Standard pin-out is pin 4 = data 2 cold (-) and pin 5 = data 2 hot (+).

To split the link into branches, use an opto-isolated splitter such as the Martin™ DMX 5.3 Splitter. Terminate the link by installing a termination plug in the output socket of the last fixture. The termination plug, which is a male XLR plug with a 120 Ohm, 0.25 Watt resistor soldered between pins 2 and 3, “soaks up” the control signal so it does not reflect and cause interference. If a splitter is used, terminate each branch of the link.

Connecting the data link

To connect the fixture to data:

1. Connect the DMX data output from the controller to the closest fixture's male XLR DMX input connector.
2. Connect the first fixture's DMX output to the DMX input of the next fixture and continue connecting fixtures output to input.
3. Terminate the last fixture on the link with a DMX termination plug.

Fixture setup

This section explains the fixture settings and utilities that the user has access to via the control panel. Settings are retained when the fixture is powered off.

Only commonly used menu options for fixture setup are described in this section. A complete map of the control menu structure and brief explanations of their purposes can be found in 'Control menus on page 38.

Using the control menus

To access the control menus, press the MENU button.

Navigate the menu structure using the ENTER, DOWN and UP buttons.

To select a menu option or to confirm a selection, press the ENTER button.

To return to a higher level in the menu structure without making a change, press the MENU button.

To exit the control menus completely, press and hold the MENU button.

DMX address

Each fixture must be assigned a DMX address. The DMX address, also known as the start channel, is the first channel used to receive instructions from a DMX controller. The fixture is controlled using 21 DMX channels. If a fixture has a DMX address of 1, it uses channels 1 through 21. The following fixture in the DMX chain could then be set to a DMX address of 22.

For independent control, each fixture must be assigned its own control channels. Two fixtures of the same type may share the same address if identical behavior is desired. Address sharing can be useful for diagnostic purposes and symmetric control, particularly when combined with the inverse pan and tilt options.

To set the fixture's DMX address:

1. Enter the control menu and select **DMX FUNCTION**. Press ENTER.
2. Select **DMX ADDRESS** and press ENTER.
3. Scroll up or down to the desired address setting.
4. Press ENTER to confirm your selection.

Lamp settings

Five minutes after the temperature in the head reaches the **LAMP OFF TEMPERATURE**, which is fixed at 130° C (266° F), the lamp shuts down automatically to protect from heat damage. The lamp restrikes automatically when the temperature cools to the **MAX ON AT TEMPERATURE**, which is fixed at 45° C (113° F).

When the LCD display shows **OFF**, the lamp must be turned on manually.

On/Off

The lamp cannot be turned on if the head temperature is over 45° C (113° F). To turn the lamp on or off via the control panel:

1. Enter the control menu and select **Lamp Settings**. Press ENTER.
2. Select **ON** or **OFF** and press ENTER.
3. Press ENTER to confirm or press MENU to exit.

State at Power

By default, the lamp strikes automatically when power is applied to the fixture. To enable or disable this feature:

1. Enter the control menu and select **Lamp Settings**. Press ENTER.
2. Select **State at Power** and press ENTER.
3. Select **OFF** to disable automatic lamp strike at power up, or **ON** to enable.
4. Press ENTER to confirm or press MENU to exit.

On via DMX On

The lamp strikes automatically when the fixture receives DMX. To enable or disable this feature:

1. Enter the control menu and select **Lamp Settings**. Press ENTER.
2. Select **On Via DMX On** and press ENTER.
3. Select **ON** to enable automatic lamp on with DMX or **OFF** to disable it.
4. Press ENTER to confirm or press MENU to exit.

Off via DMX

By default, the lamp can be turned off from the controller. To disable this feature:

1. Enter the control menu and select **Lamp Settings**. Press ENTER.
2. Select **Off Via DMX** and press ENTER.
3. Select **OFF** to disable DMX lamp control or **ON** to enable it.
4. Press ENTER to confirm or press MENU to exit.

Fixture settings

Loss of DMX

If the fixture loses the DMX signal, it can either hold the look it was displaying or black out. The default is **HOLD**. To change the setting:

1. Enter the control menu and select **Fixture Set**. Press ENTER.
2. Select **Loss of DMX** and press ENTER.

3. Select **Black Out** or **Hold**.
4. Press ENTER to confirm or press MENU to exit.

Pan inverse, tilt inverse

These settings allow you to reverse DMX pan and tilt control. The default setting is **OFF**. To reverse pan or tilt control:

1. Enter the control menu and select **Fixture Set**. Press ENTER.
2. Select **Status Settings** and press ENTER.
3. Select **Pan inverse** or **Tilt inverse** and press ENTER.
4. Select **ON** to reverse control, or **OFF** for normal control.
5. Press ENTER to confirm or press MENU to exit.

P/T Feedback

This setting allows you to turn off automatic pan/tilt correction. The default value is **ON**. To change the setting:

1. Enter the control menu and select **Fixture Set**. Press ENTER.
2. Select **Status Settings** and press ENTER.
3. Select **P/T Feedback** and press ENTER.
4. Select **OFF** to disable automatic position correction or **ON** to enable it.
5. Press ENTER to confirm or press MENU to exit.

Hibernation

By default, the fixture turns off the lamp and goes into low power mode 15 minutes after loss of DMX. The fixture automatically resets and returns to full power when DMX is restored. To disable this feature or change the delay:

1. Enter the control menu and select **Fixture Set**. Press ENTER.
2. Select **Status Settings** and press ENTER.
3. Select **Hibernation** and press ENTER.
4. Select **OFF** to disable hibernation. To enable hibernation, select a delay time of 1 to 99 minutes.
5. Press ENTER to confirm or press MENU to exit.

BI.O.P/T Move

This setting enables automatic blackout during pan or tilt movement. The default is **OFF**. To change the setting:

1. Enter the control menu and select **Fixture Set**. Press ENTER.
2. Select **BI.O.P/T Move** and press ENTER.
3. Select **ON** to enable automatic blackout, or **OFF** to disable it.
4. Press ENTER to confirm or press MENU to exit.

BI.O. Other Move

This setting enables automatic blackout during gobo and color changes. The default is **OFF**. To change the setting:

1. Enter the control menu and select **Fixture Set**. Press ENTER.
2. Select **BI.O.Other Move** and press ENTER.
3. Select **ON** to enable automatic blackout, or **OFF** to disable it.
4. Press ENTER to confirm or press MENU to exit.

Backlight auto off

The color LCD display automatically dims after a delay of from 2 to 60 minutes after the last key press. The default delay is 5 minutes. To change the delay:

1. Enter the control menu and select **Fixture Set**. Press ENTER.
2. Select **Display Setting** and press ENTER.
3. Select **Backlight auto off** and press ENTER.
4. Select a delay from 2 to 60 minutes.
5. Press ENTER to confirm or press MENU to exit.

Clear Err. Info

A password must be entered to clear error codes from the display. The password is "050". To clear error codes from the display:

1. Enter the control menu and select **Fixture Set**. Press ENTER.
2. Select **Service Setting** and press ENTER.
3. At the **Password** prompt, press ENTER, scroll to **050** and press ENTER.
4. Select **Clear Err. Info** and press ENTER.
5. Select **YES** to clear the error codes, or **NO** to keep them.
6. Press ENTER to confirm or press MENU to exit.

Factory settings

To restore all settings to factory defaults:

1. Enter the control menu and select **Fixture Set**. Press ENTER.
2. Select **Service Setting** and press ENTER.
3. Select **Factory settings** and press ENTER.
4. Select **YES** to if you want to restore factory settings, or **NO** to keep settings as they are.
5. Press ENTER to confirm.

Fixture readouts

Total use time

To display the fixture's total operating hours:

1. Enter the control menu and select **Information**. Press ENTER.
2. Select **Time Information** and press ENTER.
3. Select **Total Use Time** and press ENTER.

Lamp on hours

To display the number of hours since the lamp hours counter was reset:

1. Enter the control menu and select **Information**. Press ENTER.
2. Select **Time Information** and press ENTER.
3. Select **Lamp On Hours** and press ENTER.

To reset lamp hours after installing a new lamp:

1. Enter the control menu and select **Information**. Press ENTER.
2. Select **Time Information** and press ENTER.
3. Select **Reset Lamp Time** and press ENTER.
4. At the **PASSWORD** prompt press ENTER. Scroll to **038** and press ENTER.
5. Select **YES** to reset the lamp counter, or **NO** to cancel.
6. Press ENTER to confirm or press MENU to exit.

Head Temperature

To display the temperature inside the head:

1. Enter the control menu and select **Information**. Press ENTER.
2. Select **Head Temperature** and press ENTER. The temperature is displayed.
3. Press MENU to exit.

Offset menu

If an effect does not reset to its home position, you can calibrate it with a position offset. The offset password is 050. To enter an offset:

1. Enter the control menu and select **Offsetting**. Press ENTER.
2. At the **Calibration Password** prompt, scroll to **050** and press ENTER.
3. Select an effect to adjust and press ENTER.
4. Use the UP and DOWN arrow buttons to increase or decrease the offset value. When the effect reaches its home position, press ENTER.
5. Press MENU to exit.

Effects

This section describes the effects provided by the RUSH™ MH 7 Hybrid. See 'DMX protocol' on page 33 for a full list of the DMX channels and values required to control the different effects.

Hybrid functionality

Beam

Beam operation provides narrow-to-medium beam angles. Fixed gobos are available, giving you eight pattern gobos and five iris gobos that you can select if you want to further narrow the beam. Rotating gobos are not available.

To enable Beam operation, select 'Open' on the rotating gobo wheel (DMX channel 5).

Spot

Spot operation also provides narrow-to-medium beam angles but a beamsmoother lens is deployed, giving a more even projection. Fixed and rotating gobos are available.

To obtain Spot operation, select 'Spot' or a rotating gobo (indexing, rotation or shake) on the rotating gobo wheel (DMX channel 5).

Wash

Wash operation provides a diffuse wash effect and gives the widest beam angle.

To obtain Wash operation, select 'Enable Frost' on DMX channel 12. For the widest beam angle, set the rotating gobo wheel to 'Open' on DMX channel 5.

Dimming

Overall intensity can be precisely adjusted from 0 to 100% using 16-bit coarse and fine control.

Strobe effects

A mechanical shutter provides instant open and blackout, random and variable speed strobe from 1 to 12 flashes per second, and pulse effects.

Gobos

The fixture contains two gobo wheels: a static gobo wheel and a rotating gobo wheel that is available in Spot operation. Gobos are available in Wash Operation but have little effect. See 'Hybrid functionality' above.

Note: When the 'Bl.O. Other Move' personality setting is ON, the fixture blacks out during color and gobo changes.

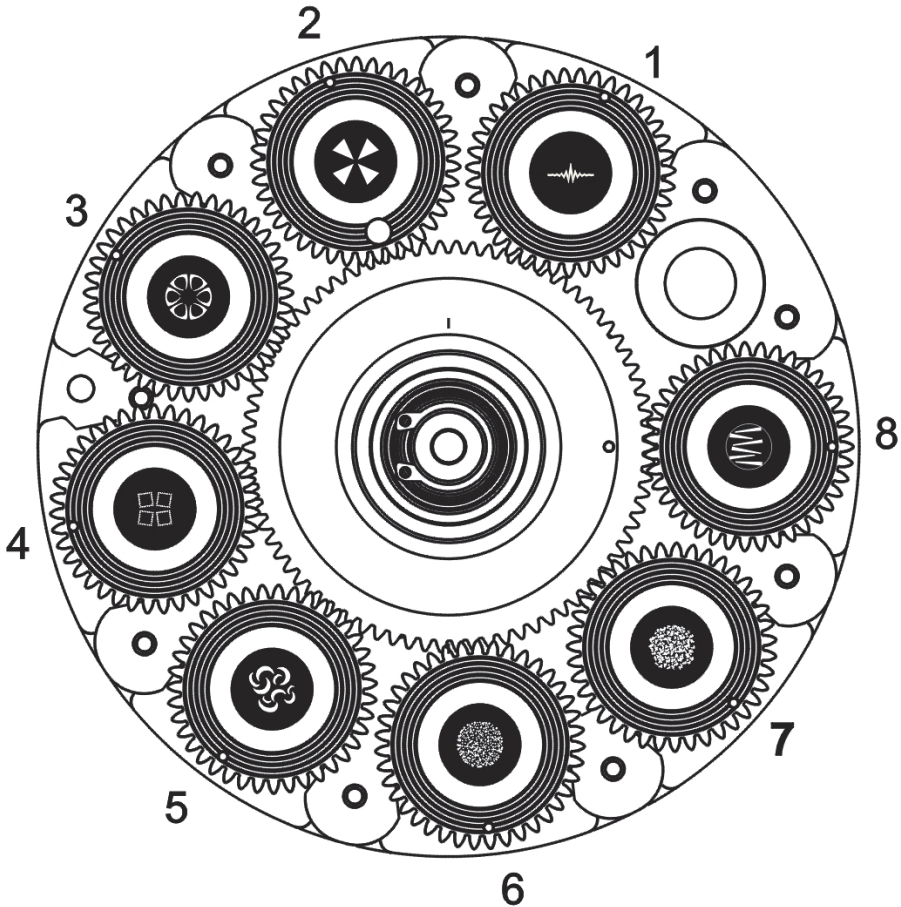

Rotating gobo wheel

The Rotating gobo wheel provides eight user-replaceable rotating glass gobos that can be set to indexed positions, continuously rotated or set to shake in Spot operation.

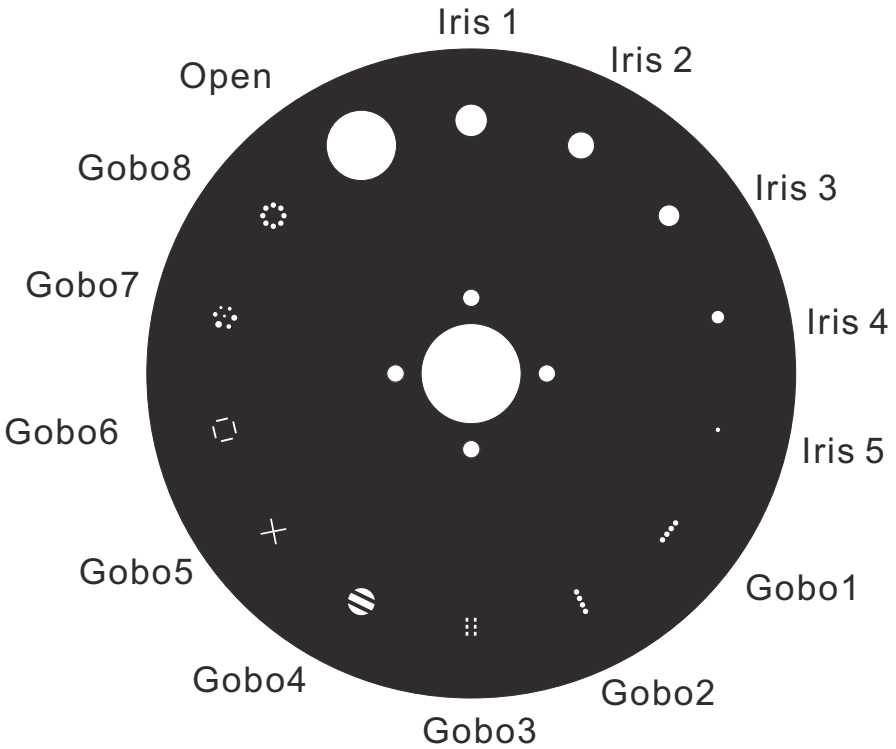

Fixed gobo wheel

The fixed gobo wheel provides a full open position, five iris gobos and eight pattern gobos.

The wheel can be scrolled in full-position steps or scrolled continuously to give split gobo patterns. It can be rotated with variable speed and direction. It can also be set to display random gobos at slow, medium and fast speeds.

Colors

The color wheel provides the 13 colors filters listed below and an open white position.

Colors can be selected in full position steps or continuously scrolled for split colors. The color wheel can be rotated with variable speed and direction. It can also be set to display random colors at slow, medium and fast speeds.

Slot 1: red	Slot 6: light blue	Slot 11: CTO
Slot 2: blue	Slot 7: pink	Slot 12: CTB
Slot 3: green	Slot 8: orange	Slot 13: UV
Slot 4: magenta	Slot 9: aqua	
Slot 5: yellow	Slot 10: purple	

Prisms

The RUSH™ MH 7 Hybrid has two prisms: a four-facet linear prism and an eight-facet radial prism. Both prisms can be set to indexed positions or rotated continuously with variable speed and direction.

Frost

Deploying the frost filter sets the fixture to Wash operation and provides a wider beam with a softer, diffuse light.

Focus

A motorized focus lens provides 16-bit coarse and fine adjustment of gobo image sharpness.

Morphing effects are available by selecting a static gobo at the same time as a rotating gobo and then shifting focus.

Zoom

A motorized zoom lens provides 16-bit coarse and fine control of the beam angle. The beam angle range is as follows:

- Cutoff angle, Beam operation: 2.2° - 24°
- Cutoff angle, Spot operation: 2.5° - 24°
- One-tenth peak angle, Wash operation: 15° - 45°

Pan and tilt

The fixture's head can be panned through 540° and tilted through 250° with 16-bit coarse and fine control. Using the control menus it is possible to invert pan or tilt movement. A position feedback circuit provides automatic position correction.

Light output can be set to black out when the head moves using either the 'Auto-blackout = ON' command on DMX channel 21, or the ***B.I.O.P/T Move*** personality setting in the control menu.

Maintenance



Warning! Read 'Safety information' on page 4 before servicing the fixture.

Disconnect the fixture from mains power before cleaning or servicing.



Service fixtures in an area where there is no risk of injury from falling parts, tools or other materials.



The user may carry out the service operations described in this manual. All other service operations must be carried out by an authorized Martin™ service technician. Do not try to repair the fixture yourself, as you may create a safety risk or cause damage that is not covered by the product warranty.



Installation, on-site service and maintenance can be provided worldwide by the Martin Professional™ Global Service organization and its approved agents, giving owners access to Martin's expertise and product knowledge in a partnership that will ensure the highest level of performance throughout the product's lifetime. Please contact Martin™ for details.

Cleaning

Excessive dust, smoke fluid, and particle buildup degrades performance, causes overheating and will damage the fixture. Damage caused by inadequate cleaning or maintenance is not covered by the product warranty.

External optical lenses must be cleaned periodically to optimize light output. Cleaning schedules for lighting fixtures vary greatly depending on the operating environment. It is therefore impossible to specify precise cleaning intervals for the fixture. Environmental factors that may result in a need for frequent cleaning include:

- Use of smoke or fog machines.
- High airflow rates (near air conditioning vents, for example).
- Presence of cigarette smoke.
- Airborne dust (from stage effects, building structures and fittings or the natural environment at outdoor events, for example).

If one or more of these factors is present, inspect fixtures within their first 100 hours of operation to see whether cleaning is necessary. Check again at frequent intervals. This procedure will allow you to assess cleaning requirements in your particular situation. If in doubt, consult your Martin dealer about a suitable maintenance schedule.

Use gentle pressure only when cleaning, and work in a clean, well-lit area. Do not use any product that contains solvents or abrasives, as these can cause surface damage.

To clean the fixture:

1. Disconnect the fixture from power and allow it to cool for at least 10 minutes.
2. Vacuum or gently blow away dust and loose particles from the outside of the fixture and the air vents at the back and sides of the head and in the base with low-pressure compressed air.
3. Clean surfaces by wiping gently with a soft, clean lint-free cloth moistened with a weak detergent solution. Do not rub glass surfaces hard: lift particles off with a soft repeated press. Dry with a soft, clean, lint-free cloth or low-pressure compressed air. Remove stuck particles with an unscented tissue or cotton swab moistened with glass cleaner or distilled water.
4. Check that the fixture is dry before reapplying power.

Replacing gobos

The rotating gobos supplied with the fixture can be replaced with custom glass or stainless steel gobos. See 'Interchangeable Gobos' on page 42 for gobo specifications.

Optical components have fragile coatings and are exposed to very high temperatures. Handle and store components with care. Wear cotton gloves while handling them. Keep them perfectly clean and free of oil and grease to reduce the risk of heat damage.

To replace a rotating gobo:

1. Disconnect the fixture from power and allow it to cool for at least 60 minutes.
2. See illustration to right. Loosen the screws indicated with an M4 TORX screwdriver and remove the top head shell.



3. The rotating gobos sit in goboholders that slot into clips in the rotating gobo wheel. Find the gobo you want to replace. Pull its goboholder away from the gobo wheel slightly, then lift the goboholder out of its clip in the wheel.

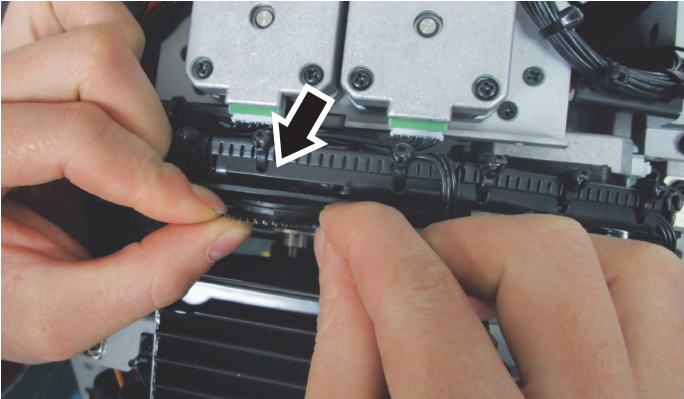

4. The gobo is held by a retaining spring. Use needle-nose pliers or a flat-bladed screwdriver to release the end of the spring.



5. Remove spring, retaining ring and gobo.



6. Insert the new gobo in the holder with the reflective side facing down (facing towards the lamp) and the dark side facing up.

7. Insert the retaining ring, making sure the tab fits in the slot in the goboholder.
8. Reinstall the retaining spring with the narrow end facing inwards, towards the retaining ring. Make sure that the outer end of the spring is held securely in place in the goboholder.
9. Reinstall the goboholder in the gobowheel, sliding the tab on the goboholder under the clip on the gobowheel and making sure that the teeth on the goboholder engage in the teeth on the gobo wheel.
10. Reinstall the head cover and be ready for the head to move when you reapply power.

Lamp replacement



Warning! Wear safety glasses and gloves when handling lamps.

Allow the fixture to cool for at least 1 hour before handling a lamp.



To avoid the risk of a discharge lamp exploding in the fixture, replace the lamp when it reaches its average lifetime (see ‘Lamp’ on page 41).



Install only lamps that are approved by Martin™ for this fixture (see ‘Lamp’ on page 41).

If a lamp breaks, ventilate the room for 30 minutes, put on nitrile gloves and remove the pieces. Put the pieces in a sealed plastic bag and take them to your local waste facilities for specialist recycling. Do not use a vacuum cleaner to clean up pieces of a broken lamp.

The lamp must be perfectly clean and totally free of oil and grease. Never touch the lamp with bare hands. If you contaminate the lamp, clean it with an alcohol wipe and then dry it with a lint-free cloth.

To replace the lamp:

1. Disconnect the fixture from power and allow it to cool for one hour.
2. Remove the lamp cover using a Phillips screwdriver.

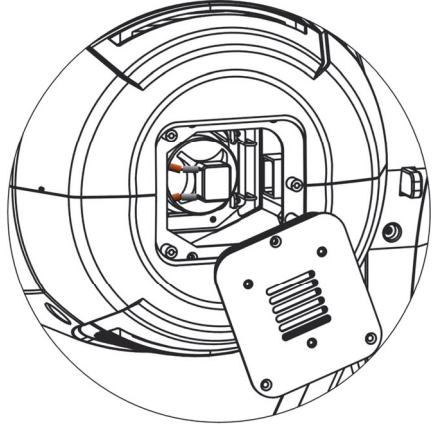
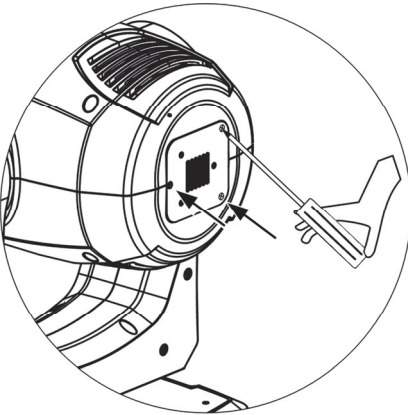

3. Squeeze and unhook the ends of the lamp retaining spring. Pivot the spring away from the lamp.

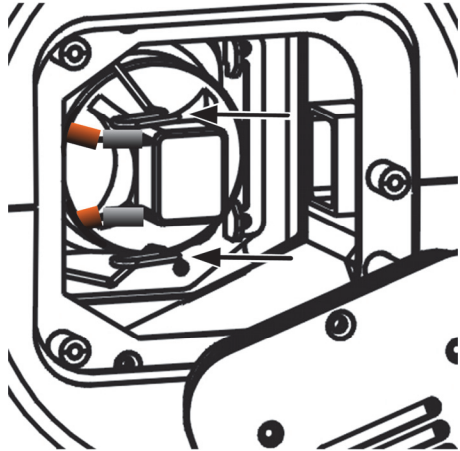
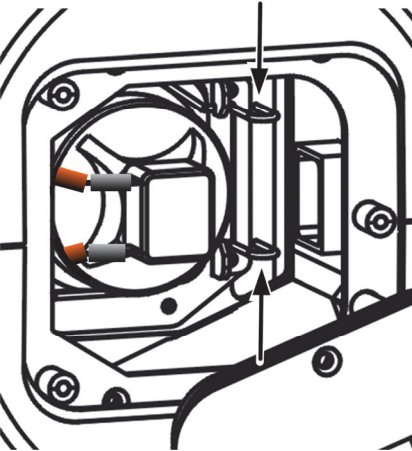

4. Carefully pull the lamp wires off of the connection pins. Remove the lamp.



5. Avoid direct contact with the new lamp. Either wear clean lint-free cotton gloves or hold the lamp with the included cloth. Remove the new lamp from its packaging and attach the wires to the connection pins.
6. With the connection pins pointing to the left, away from the retaining spring, seat the new lamp in the fixture. Secure the lamp with the retaining spring.
7. Reinstall the lamp cover before applying power.
8. Reset the lamp hours counter as described on page 21.

Replacing the primary fuse

If the fixture is completely dead, the fixture's primary fuse may have blown and it may be necessary to install a new fuse. Replace with a fuse of the same size and specified rating only.

If you need to replace the fuse:

1. Disconnect the fixture from power and allow it to cool.
2. Unscrew the cap of the fuse holder (shown on page 15) and remove the fuse.
3. Replace with a fuse of the same size and rating only.
4. Screw the fuse holder cap back on before reapplying power.

Service and repairs

Never try to repair the fixture by yourself as this may result in damage or malfunction and it may potentially void your product warranty. The equipment must only be serviced or repaired by an authorized Martin service technician.

DMX protocol

Channel	Value	Function
1	0-255	Dimmer Intensity 0 → 100%
2	0-255	Dimmer, fine Fine dimmer intensity adjustment
3	0-31 32-63 64-95 96-127 128-159 160-191 192-223 224-255	Shutter Shutter closed Shutter open Strobe effect slow → fast Pulse, fast close & slow open Pulse, fast open & slow close Sequential pulse effects Random strobe effect slow → fast Shutter open
4	0 1-11 12 13-22 23 24-32 33 34-42 43 44-52 53 54-62 63 64-73 74 75-84 85 86-95 96 97-105 106 107-114 115 116-124 125 126-136 137 138-146 147	Color wheel <i>Continuous scrolling (split colors possible)</i> Open Open → Red Red (Color 1) Red → Blue Blue (Color 2) Blue → Green Green (Color 3) Green → Magenta Magenta (Color 4) Magenta → Yellow Yellow (Color 5) Yellow → Light blue Light blue (Color 6) Light blue → Pink Pink (Color 7) Pink → Orange Orange (Color 8) Orange → Aqua Aqua (Color 9) Aqua → Purple Purple (Color 10) Purple → CTO CTO (Color 11) CTO → CTB CTB (Color 12) CTB → UV UV (Color 13) UV → Open Open

Channel	Value	Function
4 cont.		<i>Stepped scrolling (full colors only)</i>
	148-151	Red
	152-155	Blue
	156-159	Green
	160-163	Magenta
	164-167	Yellow
	168-171	Light blue
	172-175	Pink
	176-179	Orange
	180-183	Aqua
	184-187	Purple
	188-191	CTO
	192-195	CTB
	196-199	UV
		<i>Continuous rotation</i>
200-220	Clockwise color wheel rotation, fast → slow	
221-222	No rotation	
223-243	Counterclockwise color wheel rotation, slow → fast	
	<i>Random colors</i>	
244 - 247	Fast	
248 - 251	Medium	
252 - 255	Slow	
5		Rotating gobos, function and selection
		<i>Gobo indexing (set indexed position on ch. 6)</i>
	0-11	Open
	12-23	Beamsmoother
	24-29	Gobo 1, indexed
	30-35	Gobo 2, indexed
	36-41	Gobo 3, indexed
	42-47	Gobo 4, indexed
	48-53	Gobo 5, indexed
	54-59	Gobo 6, indexed
	60-65	Gobo 7, indexed
	66-71	Gobo 8, indexed
		<i>Gobo rotation (set speed and direction on ch. 6)</i>
	72-76	Gobo 1, rotating
	77-81	Gobo 2, rotating
	82-86	Gobo 3, rotating
	87-91	Gobo 4, rotating
	92-96	Gobo 5, rotating
	97-101	Gobo 6, rotating
102-106	Gobo 7, rotating	
107-111	Gobo 8, rotating	
	<i>Rotating gobo shake</i>	
112-121	Gobo 1, shake	
122-131	Gobo 2, shake	

Channel	Value	Function
5 cont.	132-141	Gobo 3, shake
	142-151	Gobo 4, shake
	152-161	Gobo 5, shake
	162-171	Gobo 6, shake
	172-181	Gobo 7, shake
	182-191	Gobo 8, shake
		<i>Rotating gobo wheel: wheel rotation</i>
	192-223	Clockwise rotation, fast → slow
	224-255	Counterclockwise rotation, slow → fast
6	0-255	Rotating gobos, indexing and speed <i>If indexed gobo selected on ch. 5</i> Gobo angle, coarse, 0°-360° <i>If rotating gobo selected on ch. 5</i>
	0-31	No rotation (0°)
	32-93	Clockwise gobo rotation, fast → slow
	94-127	No rotation
	128-189	Counterclockwise gobo rotation, slow → fast
	190-255	No rotation (90°)
7	0-255	Rotating gobos, fine indexing Fine gobo indexed angle adjustment
		Fixed gobos <i>Stepped scrolling</i>
8	0-2	Open
	3-5	Iris 1 (widest)
	6-8	Iris 2
	9-11	Iris 3
	12-14	Iris 4
	15-17	Iris 5 (narrowest)
	18-20	Gobo 1
	21-23	Gobo 2
	24-26	Gobo 3
	27-29	Gobo 4
	30-32	Gobo 5
	33-35	Gobo 6
	36-38	Gobo 7
	39-41	Gobo 8
		<i>Continuous scrolling</i>
	42	Open
	43-53	Open → Iris 1 (widest)
54	Iris 1	
55-64	Iris 1 → Iris 2	
65	Iris 2	
66-76	Iris 2 → Iris 3	
77	Iris 3	

Channel	Value	Function
8 cont.	78-88	Iris 3 → Iris 4
	89	Iris 4
	90-100	Iris 4 → Iris 5
	101	Iris 5
	102-112	Iris 5 → Gobo 1
	113	Gobo 1
	114-123	Gobo 1 → Gobo 2
	124	Gobo 2
	125-135	Gobo 2 → Gobo 3
	136	Gobo 3
	137-147	Gobo 3 → Gobo 4
	148	Gobo 4
	149-159	Gobo 4 → Gobo 5
	160	Gobo 5
	161-170	Gobo 5 → Gobo 6
	171	Gobo 6
	172-182	Gobo 6 → Gobo 7
	183	Gobo 7
	184-194	Gobo 7 → 8
	195	Gobo 8
		<i>Fixed gobo wheel continuous rotation</i>
	196-217	Clockwise rotation, fast → slow
	218-221	No rotation
	222-243	Counterclockwise rotation, slow → fast
		<i>Random slots</i>
	244-247	Fast
	248-251	Medium
	252-255	Slow
9	0-31	Rotating prisms, function and selection Open (no prism) <i>Prism indexing (set angle on ch. 10)</i>
	32-95	4-facet prism, indexed
	96-127	8-facet prism, indexed <i>Prism rotation (set speed and direction on ch. 10)</i>
	128-191	4-facet prism, rotating
	192-255	8-facet prism, rotating
10	0-255	Rotating prisms, indexing and speed <i>If indexed prism selected on ch. 9</i> Indexed position, 0° → 360° <i>If prism rotation selected on ch. 9</i> Indexed position, 0° → 360°
	0-31	No rotation (0°)
	32-93	Forwards prism rotation, fast → slow
	94-127	No rotation
	128-189	Backwards prism rotation, slow → fast
	190-255	No rotation (90°)

11	0-255	Prism indexing, fine Fine prism indexed position adjustment
12	0-127 128-255	Frost No frost Enable frost (Wash operation)
13	0-255	Zoom Zoom, narrow → wide
14	0-255	Zoom, fine Fine zoom angle
15	0-255	Focus Focus, near → far
16	0-255	Focus, fine Fine focus adjustment
17	0-255	Pan Pan, 0° → 540°
18	0-255	Pan, fine Fine pan adjustment
19	0-255	Tilt Tilt, 0° → 250°
20	0-255	Tilt, fine Fine tilt adjustment
21	0-19 20-29 30-39 40-59 60-79 80-84 85-87 88-90 91-93 94-96 97-99 100-104 105-109 110-115 116-121 122-255	Lamp on/off, reset, personality settings <i>Reserved (no function)</i> Auto-blackout on Auto-blackout off (default) Lamp on Lamp off Reset all Pan/tilt reset Reset color wheel Reset gobos Reset shutter Reset other effects Control panel display on Control panel display off Parameter shortcuts on (default) Parameter shortcuts off <i>Reserved (no function)</i>

Control menus

To access the control menus, press the MENU button. Use the UP and DOWN buttons to navigate the menus. Select a menu option with the ENTER button. For more information, see 'Using the control menus' on page 17.

Default fixture settings are shown in **bold**.

Menu	Sub-menu	Setting/Value		Explanation	
DMX Function	DMX Address	001-512		Set fixture's DMX address	
	DMX Value	PAN, TILT...		Displays DMX value received on each channel	
Information	Time Information	Total Use Time		Fixture running time in hours	
		Lamp On Hours		Lamp hours (resettable)	
		LampTime Password	038	Enter password to reset lamp hours	
		Reset Lamp Time	YES/NO	Reset lamp hours counter	
	Head Temperature		Displays head temperature in °C or °F		
	Fan Info		Speed of each cooling fan (RPM).		
	Encode Feedback	PAN ENCODE: TILT ENCODE:		Feedback encoder level	
Software Version		Displays software version of each PCB			
Lamp Control	On/Off	ON/OFF		Manually switch lamp on/off	
	State at Power	ON/OFF		Enable lamp on at power on	
	On via DMX On	ON/OFF		Enable lamp on via DMX	
	Off via DMX	ON/OFF		Enable lamp off via DMX	
	Max On at Temp.	45° C (113° F)		Maximum lamp restart temperature (fixed setting)	
	Lamp Off Temp.	130°C (266° F)		Automatic lamp thermal cutoff temperature (fixed setting)	
Fixture Set	Loss of DMX	Black out		Black out @ DMX loss	
		Hold		Hold last look @ DMX loss	
	Status Settings	Pan inverse	ON/OFF		Reverse pan control
		Tilt inverse	ON/OFF		Reverse tilt control
		P/T Feedback	ON/OFF		Toggle pan/tilt correction
		Hibernation	OFF, 1-99M (15)		Set timing for standby mode
Bl.O.P/T Move	OFF/ON		Blackout during pan or tilt		
Bl.O.Other Move	OFF/ON		Blackout during color/gobo change		

Menu	Sub-menu	Setting/Value	Explanation	
Fixture Set	Display Setting	Display inverse	AUTO/ON/OFF	Flip display 180°
		Backlight auto	02-60m (5m)	Set delay time for display off
		Temperature Unit	Celsius/ Fahrenheit	Select unit for temp. display
		Display Warning	ON/OFF	Toggle error code display
		Password	050	Enter password to clear error codes
	Service Setting	Clear Err. Info	YES/NO	Clear errors
	Factory settings	YES/NO		Reset fixture personalities to factory default values
Reset Function	Reset All		Perform a reset of selected effect(s)	
	Reset Pan&Tilt			
	Reset Colors			
	Reset Gobos			
	Reset Shutter			
	Reset Others			
Fixture Test	Auto Test		Perform automatic test of all functions	
	Manual Control	PAN, TILT...	Manually test each function	
Offsetting	Calibration Password	050	Enter password to access offset menu	
	PAN, TILT, COLOR 1...	0...255	Enter offset value to achieve home/open position	

Troubleshooting

This section describes a few common problems that may occur during operation and provides some suggestions for easy troubleshooting:

Symptom	Potential Causes	Remedies
No light from fixture, or fans not working.	Power supply issue such as blown fuse, faulty connector or damaged cable.	Ensure that the mains supply is connected and supplying power to the fixture. Check all power connections and cables. Check and if necessary replace the fixture fuse.
One of the control channels is unresponsive or only responds intermittently.	DMX setup or DMX link fault. Damaged step motor or cable connection between head and body.	See next section. Contact your Martin authorized distributor or service center for assistance.
Fixture does not respond to DMX control.	Incorrect DMX addressing. Fault in DMX network due to connector or cable problem. Interference from proximity to a high voltage installation.	Ensure that fixture's DMX address matches address set on DMX control device. Check that fixture DMX LED is on, and if not, check all DMX cables and connections. Ensure that DMX link is terminated. Move or shield link if it is close to an unshielded high-voltage installation. Attempt to control the fixture with another DMX control device.

Specifications

Physical

Dimensions (LxWxH).....301 x 408 x 644 mm (11.9 x 16.1 x 25.4 in.)
 Weight24 kg (52.9 lbs.)

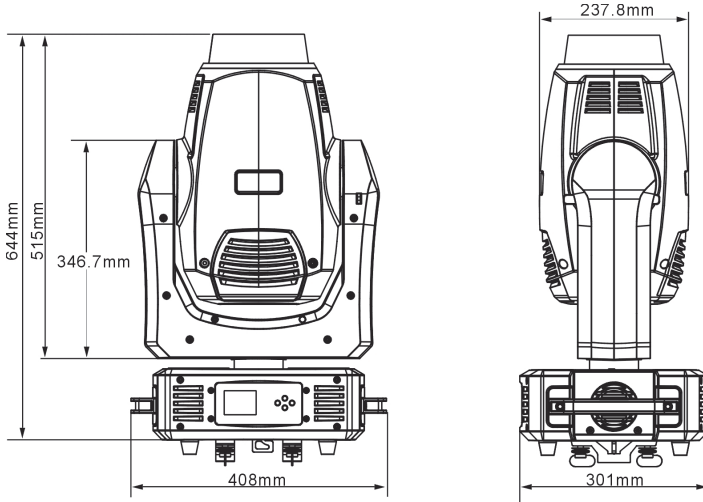

Lamp

Approved lamp Philips MSD Platinum 11R 250 W
 Color temperature 7800 K
 Average lifetime*2000 hours
**Preliminary figure obtained under manufacturer’s test conditions*

Dynamic Effects

Dimming0-100%, coarse and fine control
 Shutter..... Strobe and pulse effects, instant open and blackout
 Colors 10 colors plus CTO, CTB, UV & open
 Rotating gobos 8 gobos plus open, 16-bit indexing, rotation and shake
 Static gobos..... 5 iris gobos, 8 pattern gobos plus open, wheel rotation and shake
 Prisms 4-facet linear, 8-facet radial, 16-bit indexing, variable rotation
 Frost (Wash operation)motorized, on/off
 Zoom Motorized, 16-bit coarse and fine control
 Focus..... Motorized, 16-bit coarse and fine control
 Pan 540°, 16-bit coarse and fine control, position correction
 Tilt..... 250°, 16-bit coarse and fine control, position correction

Optics

Cutoff angle, Beam operation.....	2.2° - 24°
Cutoff angle, Spot operation.....	2.5° - 24°
One-tenth peak angle, Wash operation	15° - 45°

Interchangeable Gobos

Acceptable materials	Stainless steel or borosilicate glass with 450° C high temperature resistant coating
Diameter	14 mm, +0/-0.2 mm (0.55 in., +0/-0.0079 in.)
Max. image diameter, glass	8 mm (0.31 in.)
Max. image diameter, metal	9.5 mm (0.37 in.)
Thickness, glass	1.1 mm, +0/-0.05 mm (0.045 in., +0/-0.002 in.)
Thickness, metal	0.2 mm (0.008 in.) nominal

Control and Programming

Control	USITT DMX512/1990
DMX channels	21
Interface.....	Control panel with backlit LCD display

Construction

Color	Black
Housing	High impact flame retardant thermoplastic
IP rating	IP 20

Installation

Mounting points	Two quarter-turn brackets for rigging clamps
Location	Dry location only, must be fastened to surface or structure
Orientation	Any
Minimum distance to illuminated surfaces	10 m (33 ft.)
Minimum distance to combustible materials	20 cm (8 in.)
Minimum clearance around fans and vents	50 cm (20 in.)

Connections

AC power input / throughput	Neutrik PowerCon
DMX data in/out.....	3-pin & 5-pin locking XLR

Electrical

AC power	100-240 V nominal, 50/60 Hz
Power supply unit	Auto-ranging electronic switch mode
Fuse.....	5T 250 V 8.0 A

Typical power and current

120 V, 60 Hz.....	377 W, 3.1 A, PF 0.985
230 V, 50 Hz.....	372 W, 1.7 A, PF 0.978
Typical half-cycle RMS inrush current.....	16 A

Measurements made at nominal voltage. Figures are typical, not maximum, allow for a deviation of +/- 10%.

Thermal

Cooling	Forced air, temperature-regulated
Maximum ambient temperature (T_a max.).....	40° C (104° F)
Minimum ambient temperature (T_a min).....	0° C (32° F)
Total heat dissipation (calculated, +/- 10%).....	1430 BTU/hr.*

Approvals



EU safety.....	EN 60598-2-17 (EN 60598-1), EN 62471, EN 62493
EU EMC	EN 55015; EN 55032; EN 55103-1, -2; EN 61000-3-2, -3; EN 61000-4-2, -4, -5; EN 61547
US safety.....	UL 1573
US EMC	CFR Title 47 Part 15 Class A
Canadian safety	CSA C22.2 No. 166
Canadian EMC	ICES-003 Class A
Australia/NZ (pending)	RCM

Included Items

- Power cable, 1.5 m without mains plug
- Two omega-type clamp attachment brackets with quarter-turn fasteners

Accessories

Installation hardware

Half-coupler clamp	P/N 91602005
G-clamp (vertical hanging suspension only).....	P/N 91602003

Cables, 16 A, for connection to power in chains

Power input cable, 14 AWG, SJT, 1.5 mm ² , H05VV-F, with PowerCon input connector, 3 m (9.8 ft.).....	P/N 11541508
Power relay cable, 14 AWG, SJT, 1.5 mm ² , H05VV-F, with PowerCon connectors, 1.4 m (4.6 ft.).....	P/N 11541509
Power relay cable, 14 AWG, SJT, 1.5 mm ² , H05VV-F, with PowerCon connectors, 2.25 m (7.4 ft.).....	P/N 11541510
Power relay cable, 14 AWG, SJT, 1.5 mm ² , H05VV-F, with PowerCon connectors, 3.25 m (10.7 ft.).....	P/N 11541511

Power connectors

Neutrik PowerCon NAC3FCA power input connector, cable mount, blue	P/N 05342804
Neutrik PowerCon NAC3FCB power output connector, cable mount, light grey	P/N 05342805

Related Items

RUSH™ Software Uploader 2.....	P/N 91611770
--------------------------------	--------------

Ordering Information



RUSH™ MH 7 Hybrid in cardboard box..... P/N 90280100

Specifications subject to change without notice. For latest product specifications, see www.martin.com

Photobiological Safety Warning

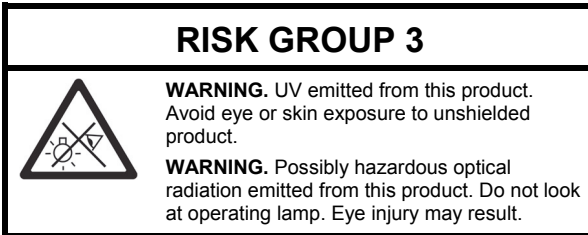
The label shown below is displayed on this product. If it becomes difficult or impossible to read, it must be replaced using the illustration below to reproduce a new label sized 88 x 34 mm, in black on a yellow background.



 	<p>Disposing of this product</p> <p>Martin™ products are supplied in compliance with Directive 2012/19/EC of the European Parliament and of the Council of the European Union on WEEE (Waste Electrical and Electronic Equipment), where applicable. Help preserve the environment! Ensure that this product is recycled at the end of its life. Your supplier can give details of local arrangements for the disposal of Martin products</p>
---	--

Martin[®]
by HARMAN